

# WideWheel User Manual

---

Single / Dual



User Manual for Single / Dual type Introduction Manual

Please read this manual before using the product.  
To improve the performance some functions might be changed without prior notice.

# WideWheel

---

Before using the product,  
please read the precautions carefully and use the product.



“We would like to thank you for choosing our product.”



If you have questions, please contact your dealer or service center.  
Also you can contact Mercane Mall at [www.mercanemall.com](http://www.mercanemall.com).

## Usage notes

- ▶ Safety Precautions ..... P. 01

## Construction

- ▶ Components ..... P. 02
- ▶ External parts ..... P. 03

## Dual assembly (※ dual model only)

- ▶ Front connection method ..... P. 04

## Control Panel

- ▶ Name and Instruments setting method ..... P. 05

## Driving

- ▶ Driving method ..... P. 06

## Folding

- ▶ Folding method ..... P. 07

## Battery

- ▶ Charging the battery ..... P. 08
- ▶ Managing Lithium ion Batteries ..... P. 09
- ▶ Charging tips ..... P. 10

## Specifications

- ▶ Product Specifications and dimensions ..... P. 11

## Exchange / Refund / Warranty / AS guide

- ▶ Product Exchange, Refund and Warranty periods ..... P. 12
- ▶ AS Tip guide ..... P. 13

– Please, read the following notes before using the products.

- 1) Please read this manual before using the product.
- 2) After you read it, please keep it where easy to find.
- 3) Under the Korean Road Traffic Law, wide heels are classified as prime movers.
- 4) In this User's manual, some device-based features and items may not be available or may be optional.
- 5) There' s some different used image in the cover and main text from actual product.
- 6) This product and its documentation subject might be changed without notice.



## WARNING

- ▶ This product is made for single use. Do not burn your passenger.
- ▶ Do not change mechanical structural.
- ▶ Do not drive in environment with a risk of accident.
- ▶ Do not Sudden turning during driving.

### ◆ Safety Prevention Principle

- ▶ Do not carry out any dangerous movements, and always put both hands on the handlebars.
- ▶ Do not drive on angled jaws(hills) or stairs
- ▶ Do not carry heavy objects on the handle bar
- ▶ Electric products may cause corrosion or breakdown in wet environment. It is recommended to use in sunny weather.

### ◆ Safety accident prevention

- ▶ Please wear safety protective gear (helmet, protector, etc.) when driving.
- ▶ Please pay attention to terrain and ground. If you are driving on unpaved roads, please drive slowly.
- ▶ Please refrain from operating on roads with many vehicles.
- ▶ The electronic control system of this product has been developed with safety first, so please do not change the electric circuit or install other electric devices.
- ▶ If the battery gauge has only one space remaining, stop operation and charge it.
- ▶ Regularly check the connection status between the wires and the connector.
- ▶ Avoid driving in places where people are crowded or where pedestrian safety is a concern.
- ▶ Do not use it on slippery places or ice roads due to water.
- ▶ Do not use it on steep grades over 15 degree.
- ▶ Do not use on rainy and snowy days.
- ▶ Be safe at low speeds on ramps.
- ▶ For safety during operation, please operate safely within 20km/h.

## – Components Information

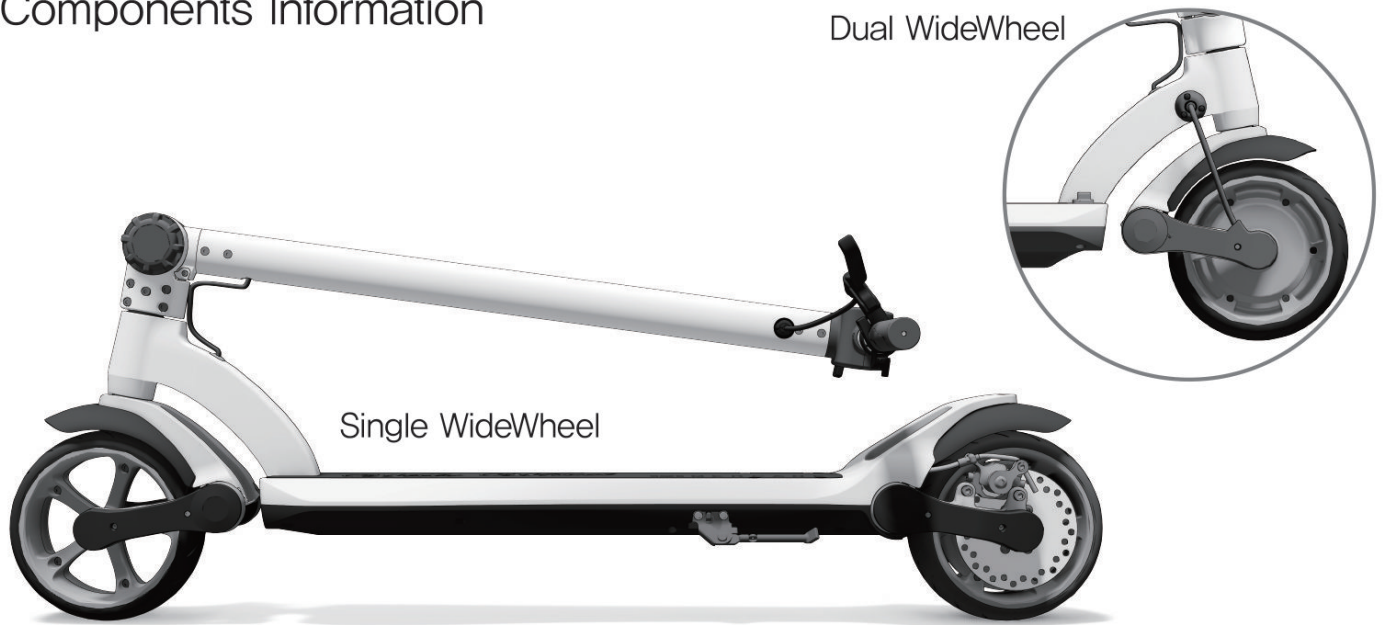

WideWheel Body Frame

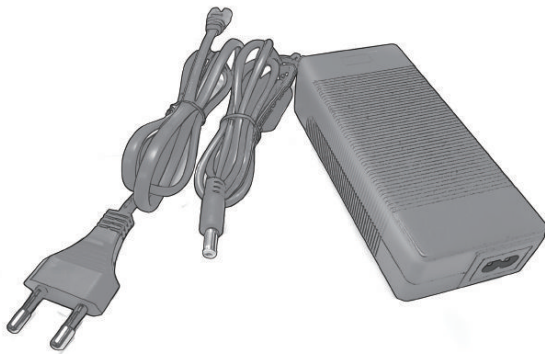

Battery and adapter



User Manual



Power cord

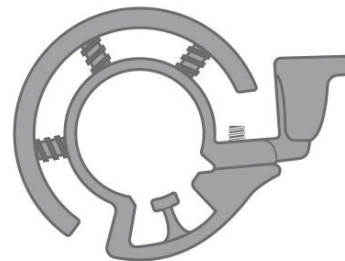

Bell

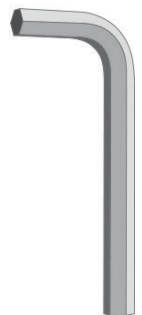

Allen wrench



### ※ Charging procedure ※

- 1) Connecting adapter to power cord
- 2) Plug the charger into the outlet.
- 3) Connecting the charger to the product

– External parts



- ① Control panel
- ② Handle
- ③ Throttle lever
- ④ Brake lever
- ⑤ Bell
- ⑥ Folding knob
- ⑦ Fender
- ⑧ Front wheel
- ⑨ Suspension
- ⑩ Charging port
- ⑪ Foot mat
- ⑫ Stand
- ⑬ Mount hole to install seat
- ⑭ Brake light
- ⑮ Brake disc
- ⑯ Rear wheel

- Ⓐ Handle Bar
- Ⓑ Handle Post
- Ⓒ Body

## – Dual front wheel assembly method

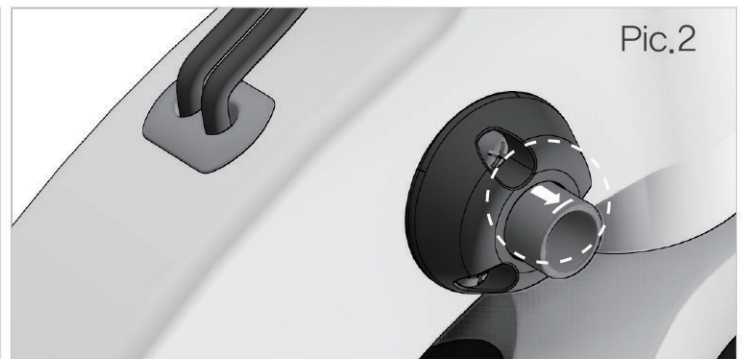
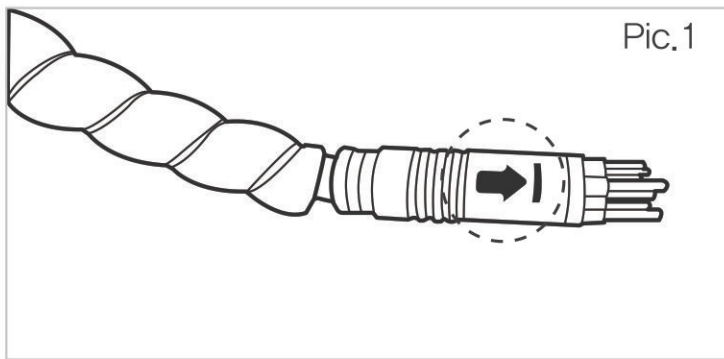
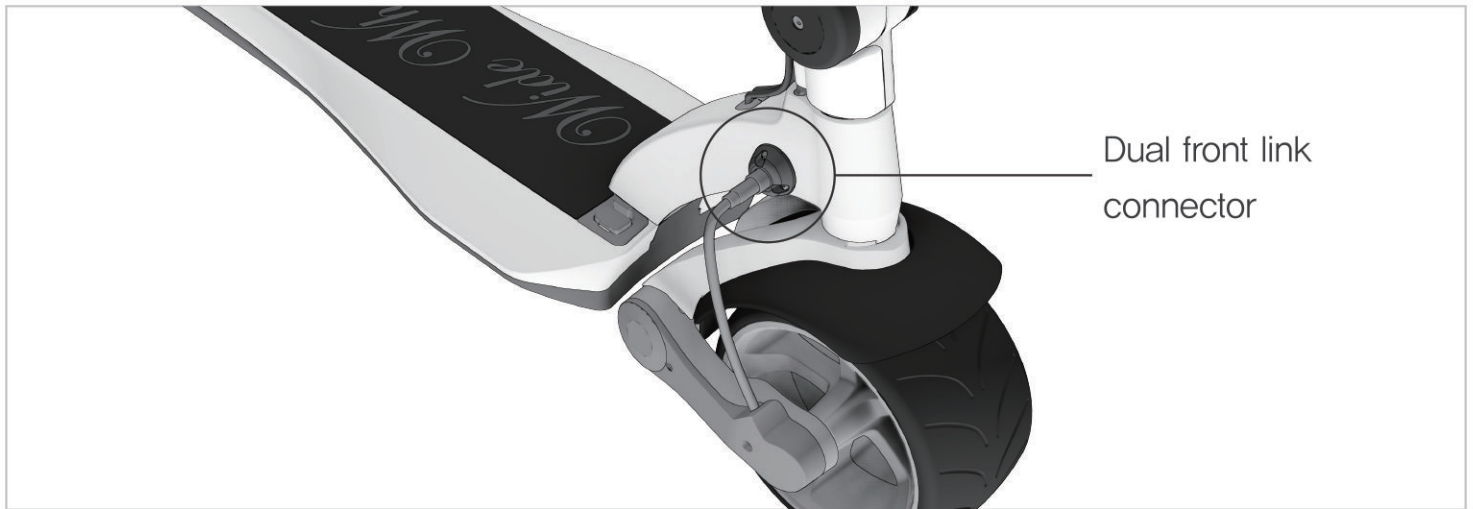

- ① Check the arrow direction of the connector coming out from the front wheel in Pic.1.
- ② Check the arrow direction of the front insertion hole in Pic.2.
- ③ Insert the arrows of the connecting parts to match the position.

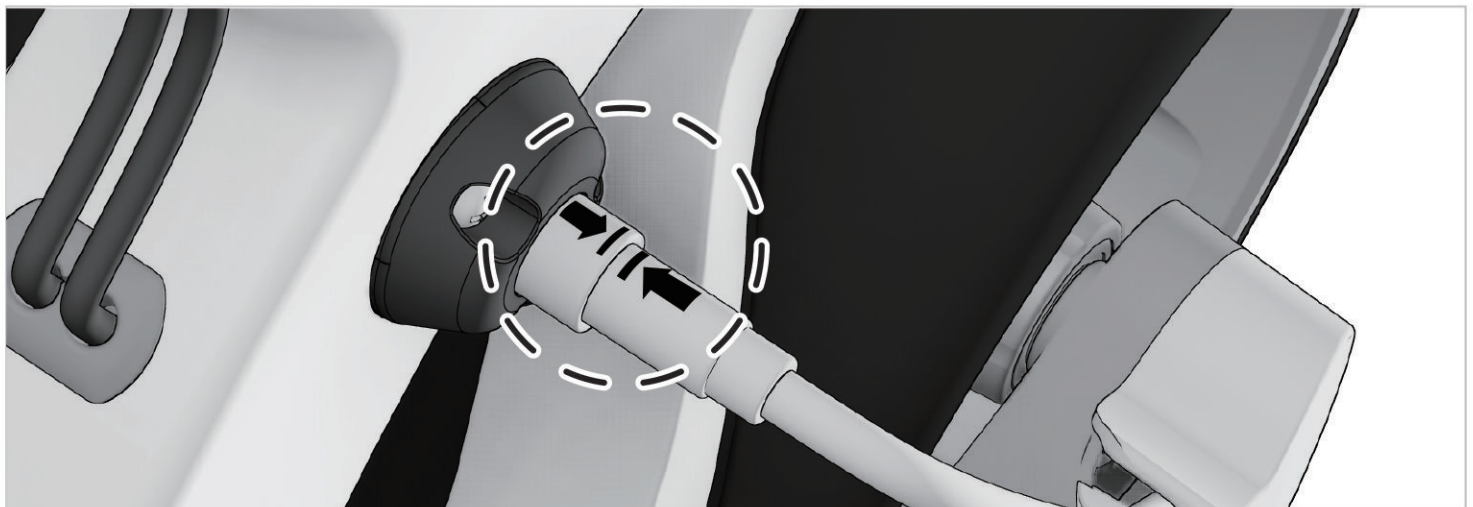

Be sure to check the arrow direction of the front wheel connector and insert it according to the position.

## – Control Panel Components

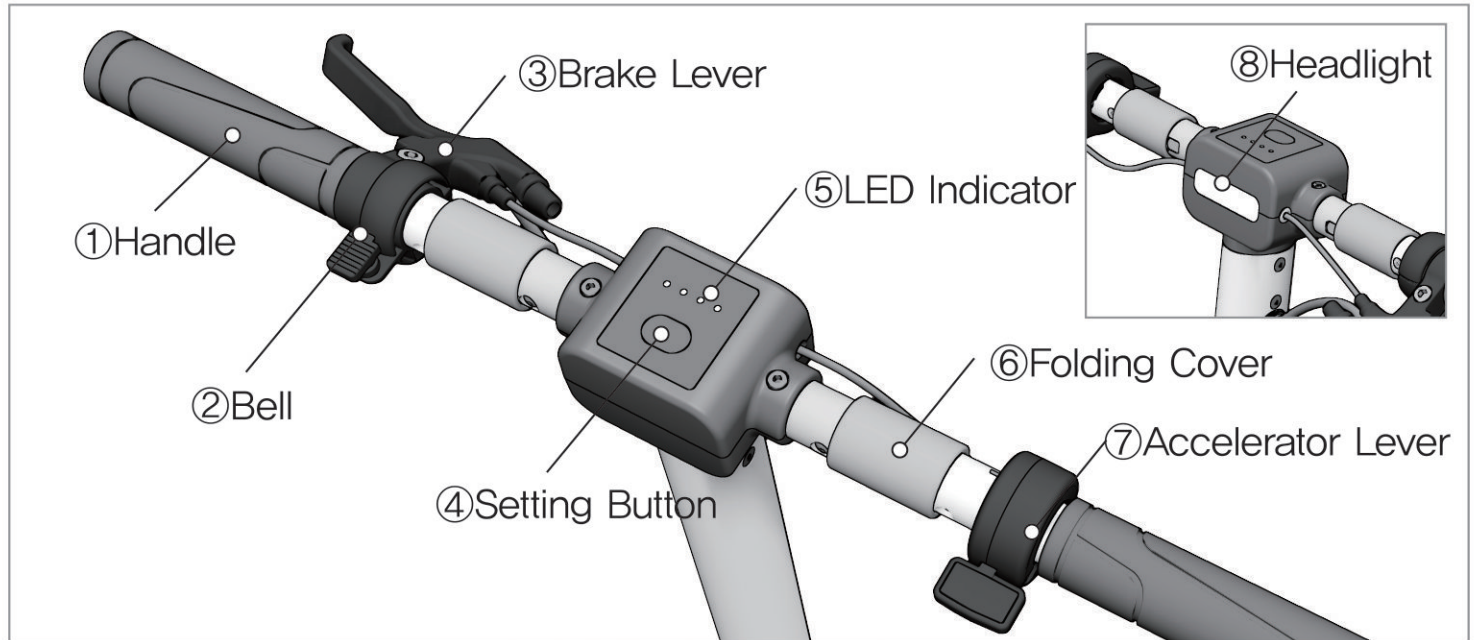

### LED Indicator (Driving mode): Battery Life Indicator

#### Power ON/OFF

- ▶ Power ON: Press the power button until the lamp turns on (ab. 2 seconds)
- ▶ Power OFF: Press the power button until the lamp turns off (ab. 2 seconds)

#### Setting Mode

- ▶ Press and hold the power button about 1 seconds to switch into setting mode. LED blinks according to setting status.
- ▶ In setting mode, press and hold the power button 1 second to switch to driving mode. LED shows remaining battery life.

#### Cruise Control

- ▶ In setting mode, if you hold the brake lever and press the switch button, it can be controlled ON/OFF.

※ For more information, please refer to the website of Mercane Co., [www.mercane.com](http://www.mercane.com), also kindly have a look on our products' gallery. ※

### LED Indicator guide ●:Red LED / ○:White LED / ●:LED Off

- |         |                                  |
|---------|----------------------------------|
| ● ● ● ● | ▶ Red LED indicates mode status  |
| ● ○ ● ● | ▶ ECO mode (Battery Life Saving) |
| ● ○ ○ ● | ▶ Power mode (maximum possible)  |
| ● ● ● ○ | ▶ Cruise mode settings           |

※ Please, refer to above indicator buttons to set modes



## – Driving instruction

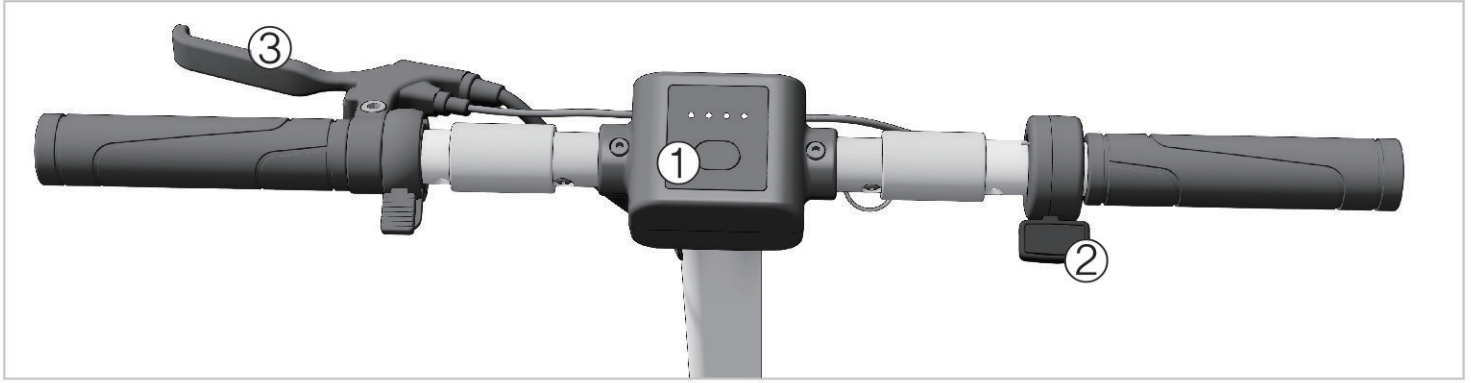

① 1. Press the Power button for 2 seconds to turn the power on.

(The power is automatically turned off after 3 minutes when not operating)

▶ Set the driving mode (ECO/POWER) by pressing the setting button and press the button one more time.

② Start driving by operating the acceleration lever

③ Decelerate and stop by using brake

▶ The headlight can be turned ON/OFF by pressing the switch button once after turning on the power.

▶ Since the product offers "Kick and go" function, it is possible to drive by using lever with the pushing by one foot and letting the kickboard go forward. Since the product offers "Kick and go" function, it is possible to drive by using lever with the pushing by one foot and letting the kickboard go forward.

◆ WideWheel can be operated by setting the driving mode directly according to the driving environment.

### ECO mode :

This is a mode that provides smooth and efficient driving by adjusting the output and acceleration.

### POWER mode:

In this mode you can use all the maximum output and torque of the product.

It is an active driving mode with a fast response to speed.

However, even in POWER mode, speed is limited automatically when speed exceeds 25 km/h.



Continuous breaking on downhill roads may cause breaking fails and accidents, so it is absolutely unnecessary to use it. Also, it may cause damage to the motor and the controller in case of unreasonable operation.

## – Handlebar folding instruction

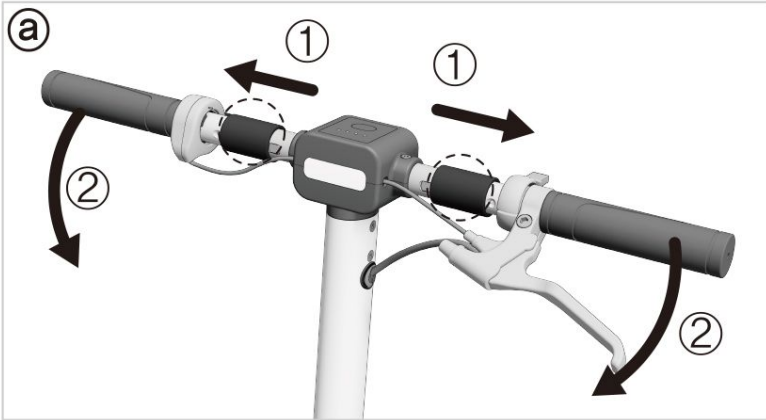

(a) Move the lock lever in the direction as shown in picture ①. Hold it and lower the handlebar grip in the direction as shown in picture ②

(b) Pull up on the handlebar the direction as shown in picture ①

## – Body frame folding instruction

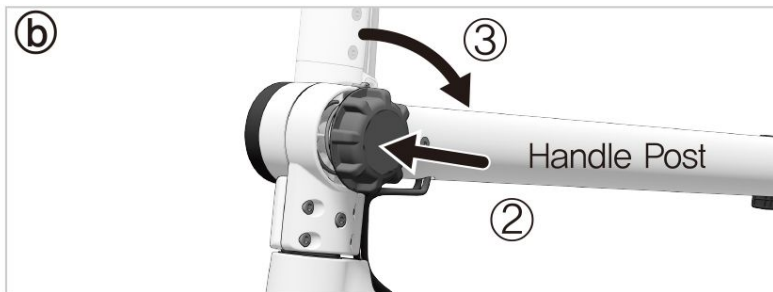

(a) Loosen the folding knob by turning it counterclockwise (7~10 times).  
Do not turn the folding knob more than 10 times since it may be released from the frame.

(b) Hold the folding bar with one hand and push the holding knob with the other hand in the direction as shown in picture ② until the handlebar frame is lowered.  
Otherwise, loosen the folding knob by checking if the handlebar frame is lowered.

(c) Lower the handlebar frame until you can hear "clicking" and then tighten the folding knob clockwise.

(d) Unfold in reverse order of folding

※Unfasten the folding dial and reassemble it according to the position when separating the folding dial and spring. (There is no problem in use because it is a type that is separated from product damage.)※

※For more information, please visit the gallery at [www.mercanemall.com](http://www.mercanemall.com).※

※When product is received, it is folded. To unlock it, turn the folding cover 6–8 times and push it. Lift the handlebar up until it locks again and tighten the folding cover.

※Please lock the folding dial firmly to prevent the folding during the driving.

## – Charging the battery



Open the charging port on the front of your Wide Wheel (as shown in the picture above) and connect the power cord into the charging port.

### ◆ Charging Instruction

- ▶ Charging port is located on the right side of the front wheel.
- ▶ Charge your batteries for 6–7 hours and do not charge your batteries for more than 10 hours to prevent the batteries from overheating.
- ▶ Charge the battery when driving slows down.
- ▶ When the Wide Wheel is plugged in and charging, charger LED will be red.
- ▶ When the battery is charged, indicator turns into green.
- ▶ Charging should be done only in well ventilated room.
- ▶ Battery pack is consumable device. Please, replace to new one when battery life time serves less than half of initial battery life.
- ▶ The product cannot be operated while the battery is charging.

### ◆ Charger connection guide

- ▶ If you connect the charger to the product and then plug the outlet, it may cause a spark. Please make sure to charge in the same way as the connection procedure below.



- ① Connecting adapter to charging port
- ② Connecting charging plug to wall outlet
- ③ Connecting charging port to product

## – Using and managing Lithium Ion batteries

 **Warning**

- ▶ Must be using the standard charger supplied with the product. Using non-standard charger may cause product malfunction and topic.
- ▶ It should be charged from 0 to 40 degrees Celsius, and should be stored at temperatures between –20 and 60 degrees Celsius. Charging or discharging at temperatures over this range may damage the battery.
- ▶ To avoid exposed to direct sunlight for a long time or in high temperatures. Charge the product and charger in a safe place with no flammable material around.
- ▶ If you enter the warm space from the cold outside in the winter season, it may cause condensation inside due to the temperature difference. Do not charge it immediately and charge it after the temperature difference decreases after a certain period of time.
- ▶ If the protection circuit is damaged If there is any leakage or smell from the battery, stop using it immediately and contact the place of purchase for technical support and service.
- ▶ Care should be taken to avoid exposure to children or pets.
- ▶ Be careful not to short-circuit the charging terminal or change the polarity, and be careful that the battery may be damaged or explode in case of external shock or short circuit.
- ▶ If multiple Li-ion batteries are assembled and the product is packed and subjected to excessive external impact, the battery will be damaged due to electrode separation and short circuit, which increases the possibility of ignition. Therefore, when the battery is installed in the product, you must not run for a long time in uneven road surface, do not carry jumps or drops, and check the battery if a strong shock from the accident is applied to the battery.
- ▶ In the event of flooding, stop using it immediately and contact your dealer for assistance. Do not connect the charger to water because there is a risk of electric shock when flooded.
- ▶ Do not disassemble it. It is prohibited to incinerate when disposing. It should be classified as industrial waste and care should be taken to avoid shorts at the terminals.
- ▶ It has a characteristic that the discharge performance is reduced by 10% or more when charging and discharging 300 times or more. If the battery usage time becomes too short due to long use, the battery should be replaced through the place of purchase.
- ▶ Energy density is very high so, there is a possibility that if the battery pack is charged for a long time under short-circuit, short-circuit, leakage, or battery failure, it may be ignited. Therefore, it should be avoided to charge the room indoors for a long time in the absence of a person, or to charge for a long time while sleeping at night.

– Battery charging precautions

## Warning

### ◆ To prevent fire and electric shock

- ▶ Be sure to use the charger and battery supplied with the product
- ▶ Do not use the battery and charger of this product for other products. Overheating, fire, explosion may occur.
- ▶ Never modify the electrical circuit. Any manipulation of the electric circuit may cause shock, fire, explosion and damage to the product.
- ▶ Do not charge the battery while it is charging. Charging should only be done in a well-ventilated room.
- ▶ Do not carry the battery by the wire or charger. Doing so may damage the battery or cause a fire. When lifting the battery, hold the battery case.
- ▶ The built-in battery may cause fire due to strong shock or high temperature.

### ◆ Handling Precautions

- ① If you are not going to use it for a long time, please separate the battery and connection cable.
- ② You must recharge and maintain it at least once a month to use the battery longer.
- ③ Since the battery is a consumable item, it is not a free A / S item. Please use it after repacking in case of complete discharge.
- ④ Operating in sub-zero weather conditions can significantly reduce battery life, so please do not use below minus 5 degrees.
- ⑤ Be sure to familiarize yourself with the characteristics of charging and discharging
- ⑥ Disassembling or tuning the product without going through the designated service center may cause the product to malfunction.

- ▶ Do not disassemble or repair the battery.
- ▶ Do not drop the battery. It may permanently damage the battery and cause serious injury.
- ▶ Before charging the battery, check the battery, charger, connector, and connectors for damage. If the battery, charger and related parts are damaged, stop charging.
- ▶ Do not completely discharge the battery. After using the battery, please be sure to fully charge the battery. If not used, charge it regularly at least once a month.

## – WideWheel SPEC (Single/Dual)

TYPE	SPECIFICATION
Motor	Single rear : 48V 500W BLDC Hub Motor / Dual front and rear
Battery	48V 211Wh / 422Wh / 633Wh (optional) Lithium Ion
Charging time	4~6 hours
Max Speed	25km/h (speed limit)
Driving Range	Single : 20 / 40km Dual : 30 / 50 Km(depends on driving condition)
Max Climbing Ability	<25% ~ <40% (Different / depending on single or dual)
Weight limits	100kg
Suspension	Link type front and rear suspension
Braking method	Disc breaking
Headlamp / Taillight	LED Lamp
Tire	100mm wide tire / aluminum
Product weight	Single : 15.9 kg / 17.2 kg Dual : 19.2 kg / 20.5 kg
Overcurrent Protection Device	Software : Auto Power OFF when current exceeds 15 A
	Battery : Protection module (PCM) installed / Power is automatically turned of due to slow battery transferring

## Product Dimensions (same external size for single / dual)

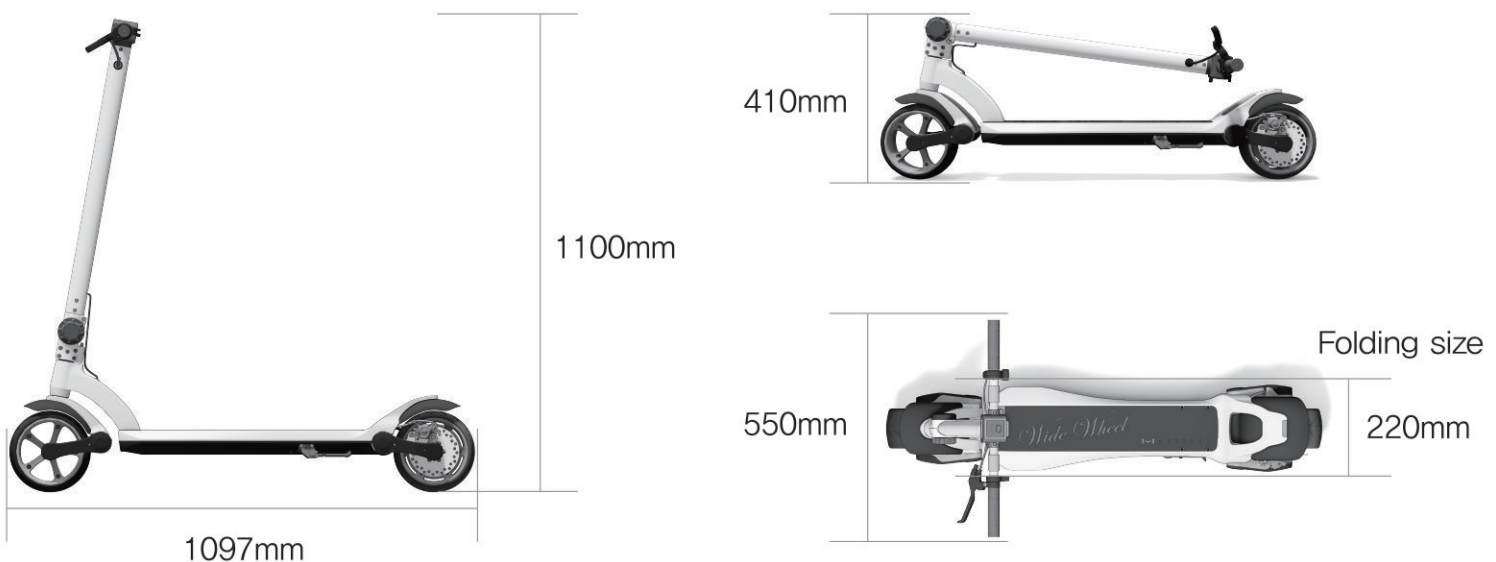

※ To improve quality and safety of the product, the specifications might be changed without prior notice.

– Product exchange, refund and warranty period

## © Exchange and Refund Policy .....

### ◆ Product exchange regulations

---

- ▶ If product is different from purchased model
- ▶ If product is damaged during delivery time
- ▶ In case of requesting hardware order within 7 days after purchase
- ▶ If trouble occurred after repairing same area three times
- ▶ If failure occurred within warranty period

Notice

- 1) The exchange is made by individual parts (exp.: if the wheels fail, only wheels will be exchanged)
- 2) For exchanges without any damages, customer has to pay round delivery fee.
- 3) If other accessories or parts are defective, they are replaced with those parts only.
- 4) Remuneration is made within 14 days from the notification date.

### ◆ Refund Policy

---

- 1) If product is different from purchased model
- 2) If it is needed to repair important hardware within 7 days after purchase
- 3) If customer wants to exchange or refund due to simple remorse without defect within 7 days after purchase. In this case, all round delivery fee is covered by customer.

### ◆ Exchange and Refund Not Applicable

---

- 1) If the accessories and parts are defective, it is not eligible for a refund.
- 2) If the software is defective it is not eligible for exchange / refund.
- 3) If the product opened and judged to be defective as a new product, it is not eligible to return.
- 4) If customer does not have a product purchase receipt or proof , customer is not able to get a refund.

---

– A.S Tip

---

◆ If power is ON, but product still does not operate

- ▷ Wide Wheel is a product with built in kick function. It can be operated after pushing the product with one foot.
- ▷ Also, the setting mode must be changed into driving mode to operate

◆ If there is noise, when rear wheel is equipped with disc brake.

- ▷ Please refer to the guideline of manual, and adjust the contact area between the pad and the disc to optimize braking operation.

◆ If the brake is pushed, a wire type disc brakes.

- ▷ Needs to adjust the sensitivity depending on the user's preference.  
Adjust the brake sensitivity by referring to the manual and Mercane's official website.

◆ When folding the product, the folding bar is disengaged.

- ▷ Wide Wheel has a scale folding system to minimize device's portable function.  
If you turn the folding dial as much as possible,  
it will be removed. Turn it 7~9 times and refer to the User Manual.

◆ If there is a problem with changing and understanding of operating modes.

- ▷ Wide Wheel uses only most necessary and intuitive dashboard. Please be sure to familiarize yourself about functions and operating methods with the manual and videos from Mercane's official websites while using the product first time. .

※If you have any further questions or inquires ,  
please contact us at [www.mercane.com](http://www.mercane.com) or Mercane Customer Canter.





The most comfortable and  
stylish E-Scooter “WideWheel”



WideWheel Introduction manual

<http://www.mercanemall.com>